



BMW M8 GTE 1/24





BMW M8 GTE 1/24

COCKPIT ASSEMBLY

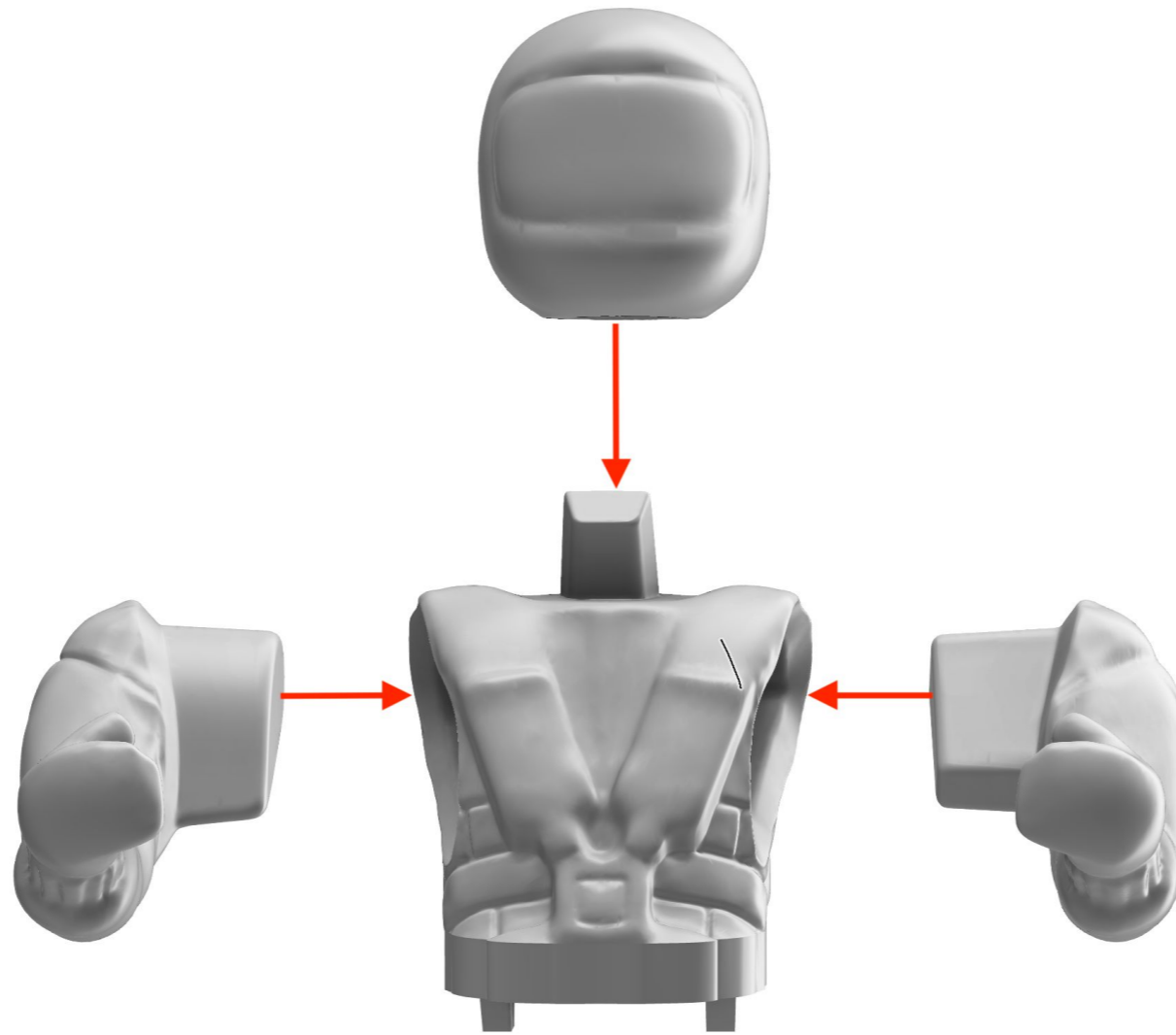



BMW M8 GTE 1/24

COCKPIT ASSEMBLY

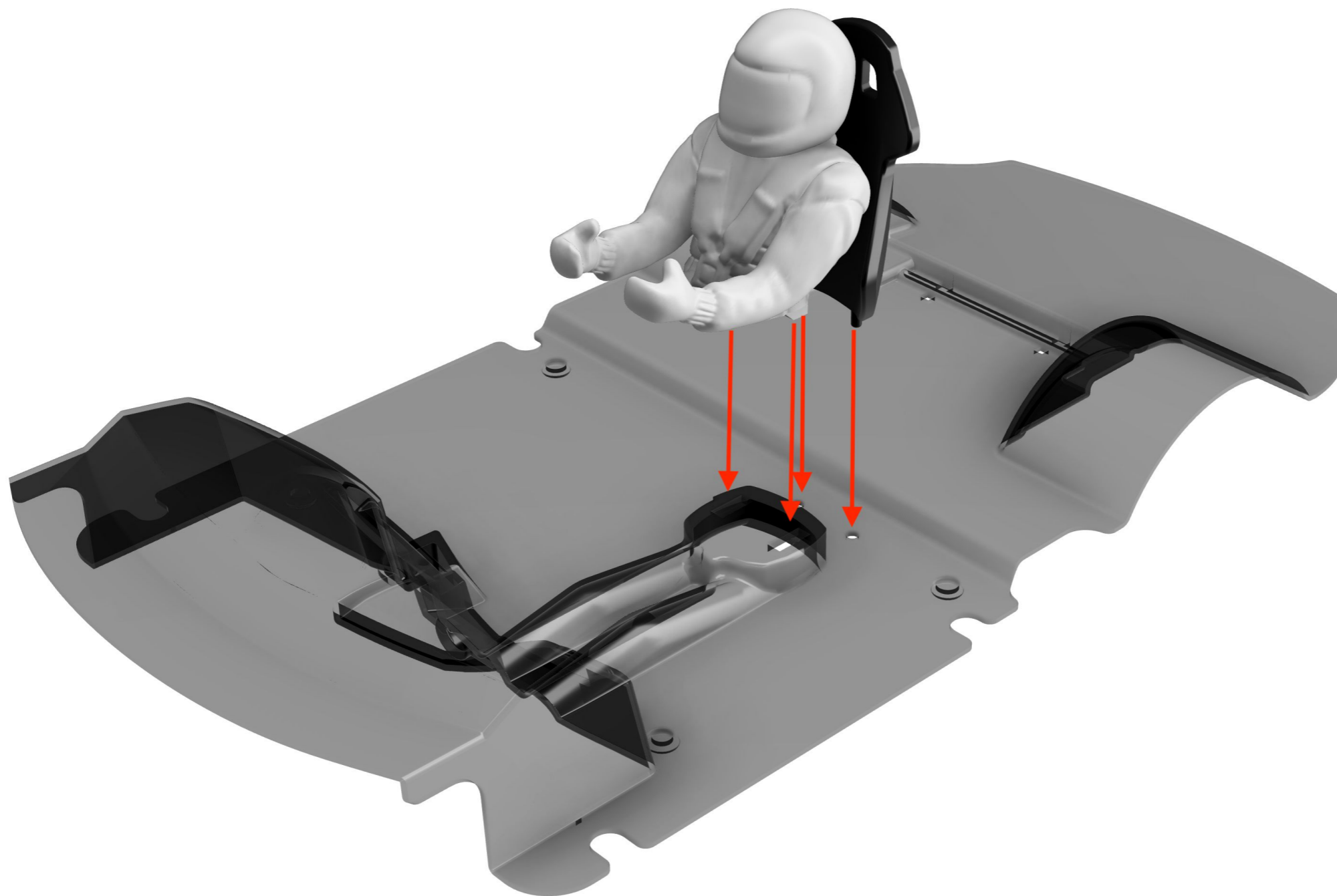



BMW M8 GTE 1/24

COCKPIT ASSEMBLY

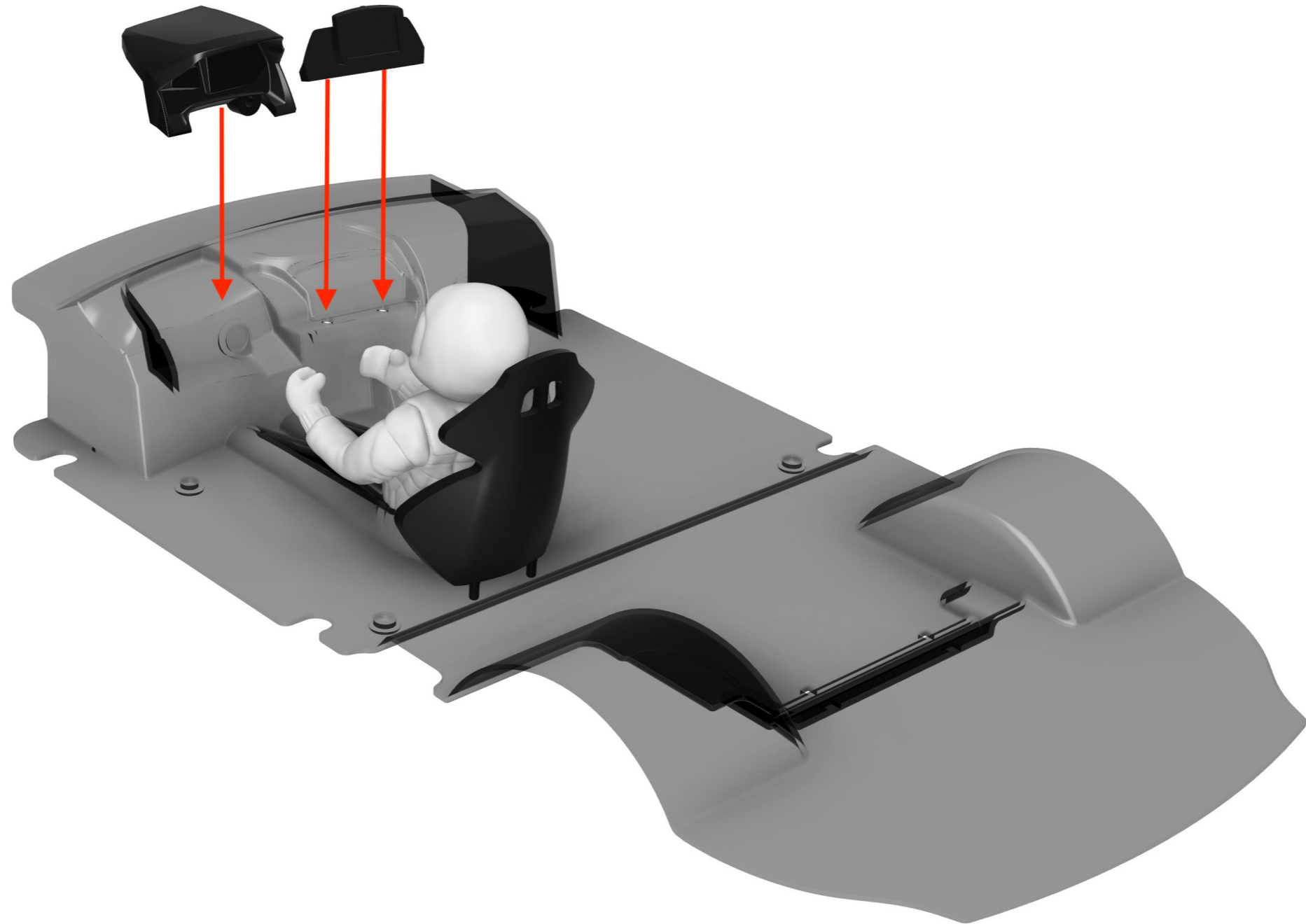



BMW M8 GTE 1/24

COCKPIT ASSEMBLY

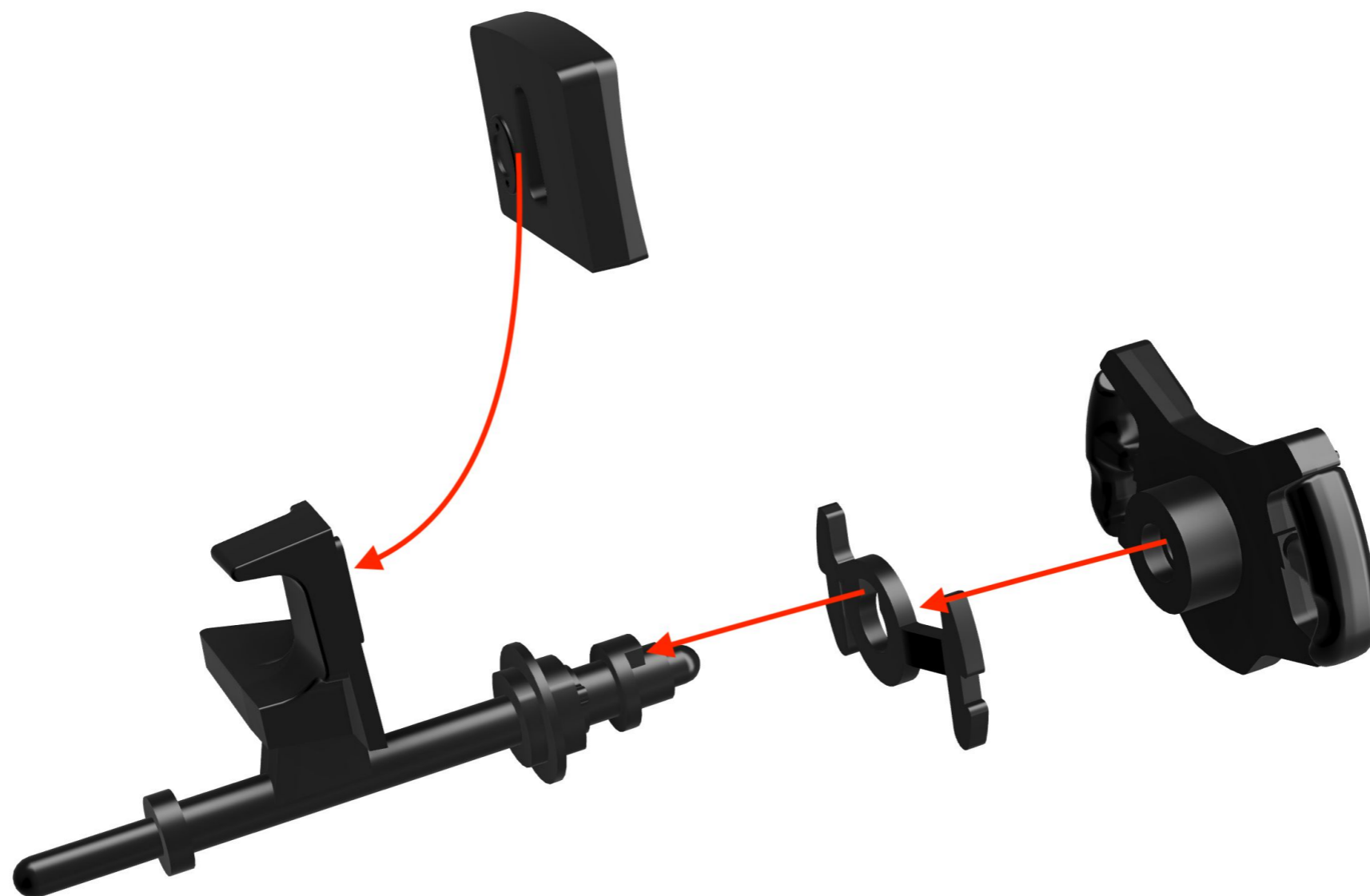



BMW M8 GTE 1/24

COCKPIT ASSEMBLY

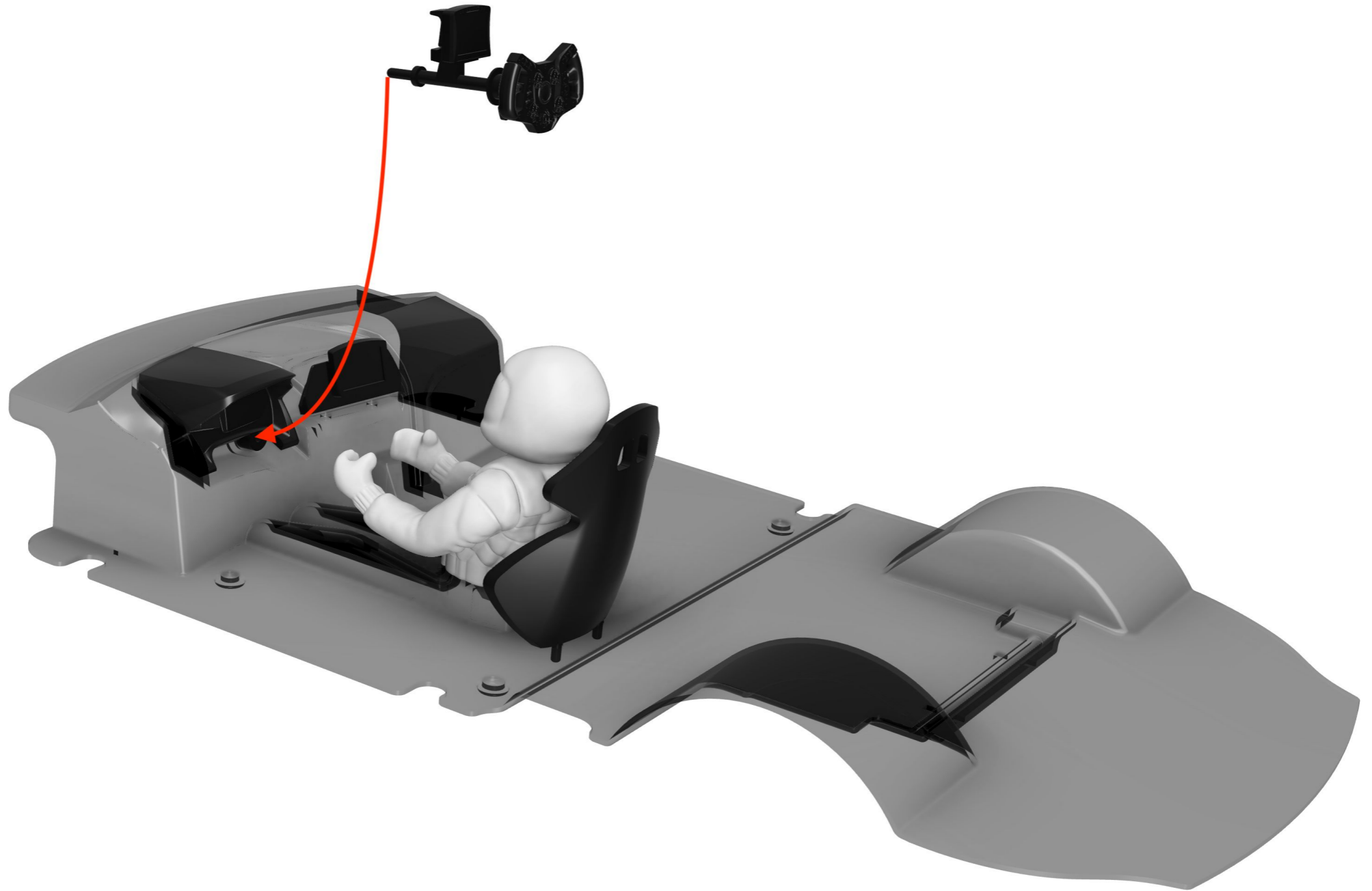



BMW M8 GTE 1/24

COCKPIT ASSEMBLY

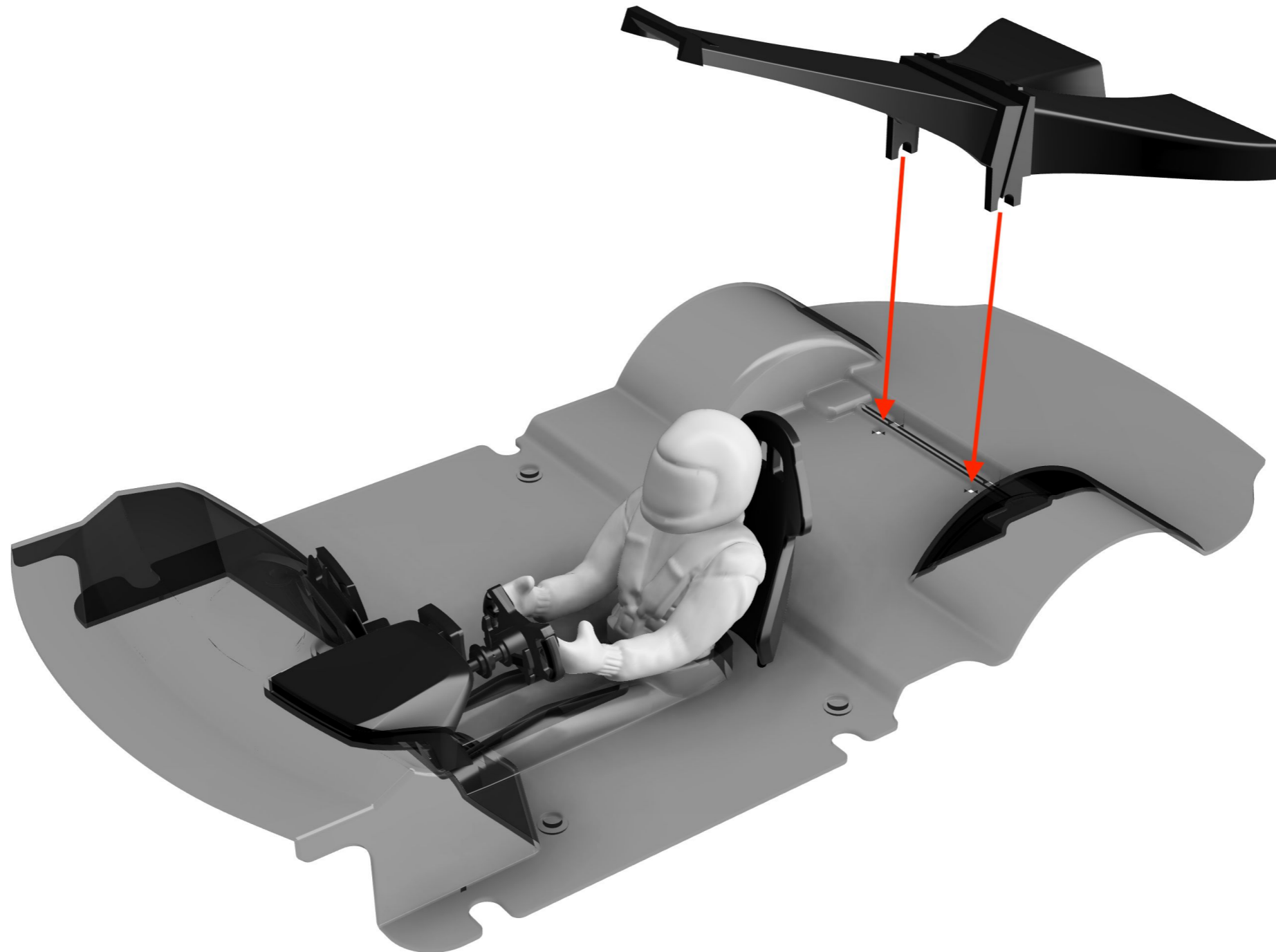



BMW M8 GTE 1/24

COCKPIT ASSEMBLY

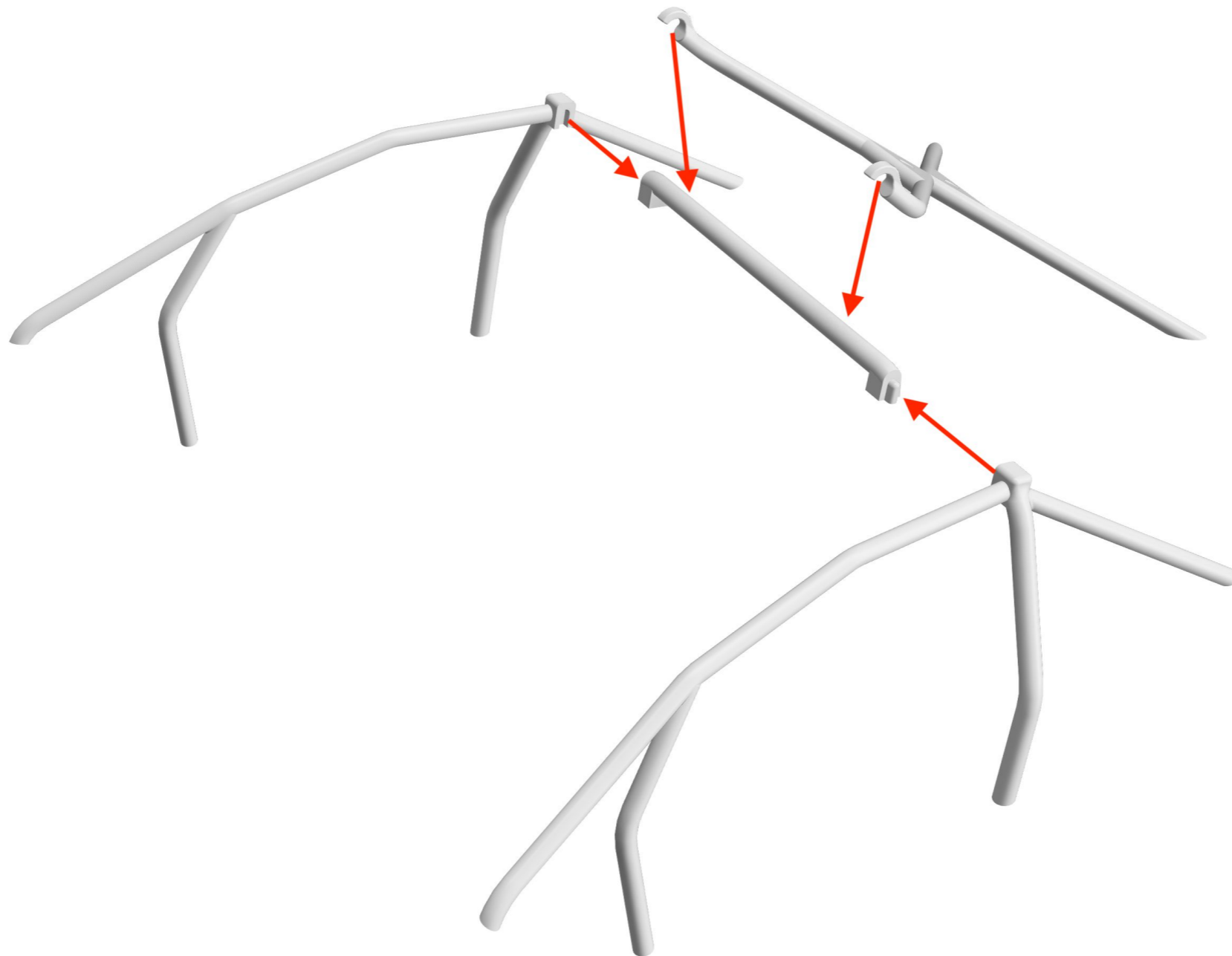

COCKPIT ASSEMBLY

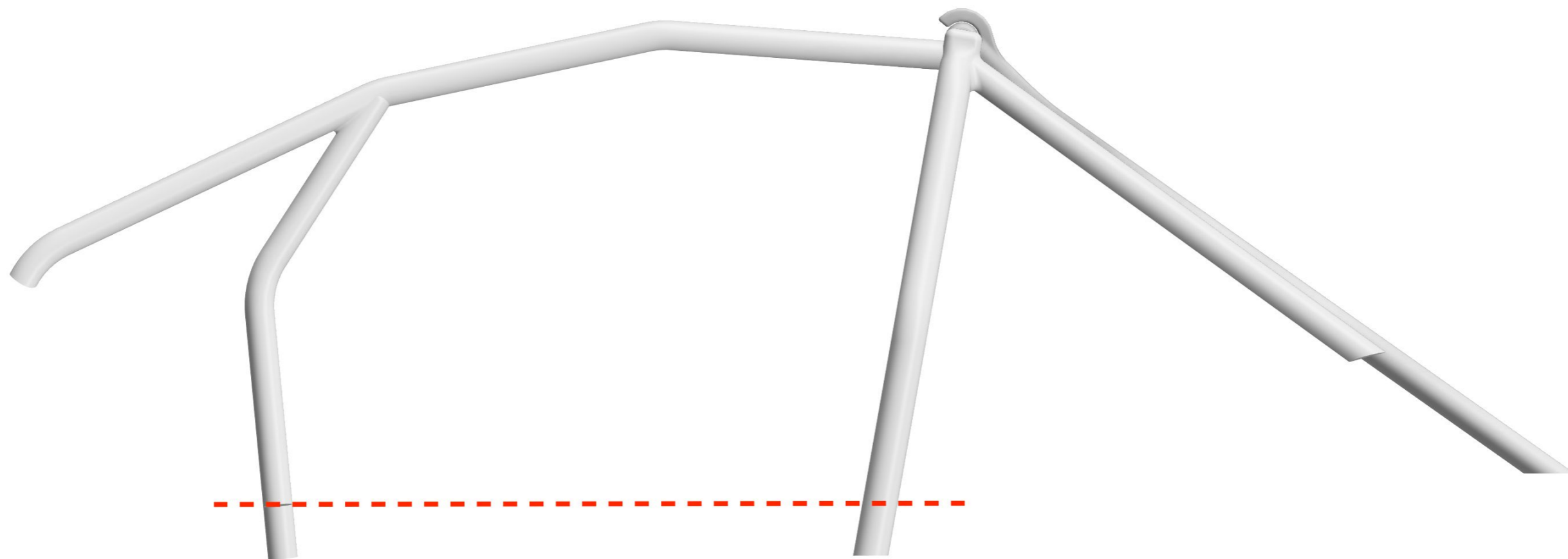

Para un ajuste perfecto se deben cortar unos 3mm

For a perfect fit should be trimmed about 3mm



BMW M8 GTE 1/24

COCKPIT ASSEMBLY

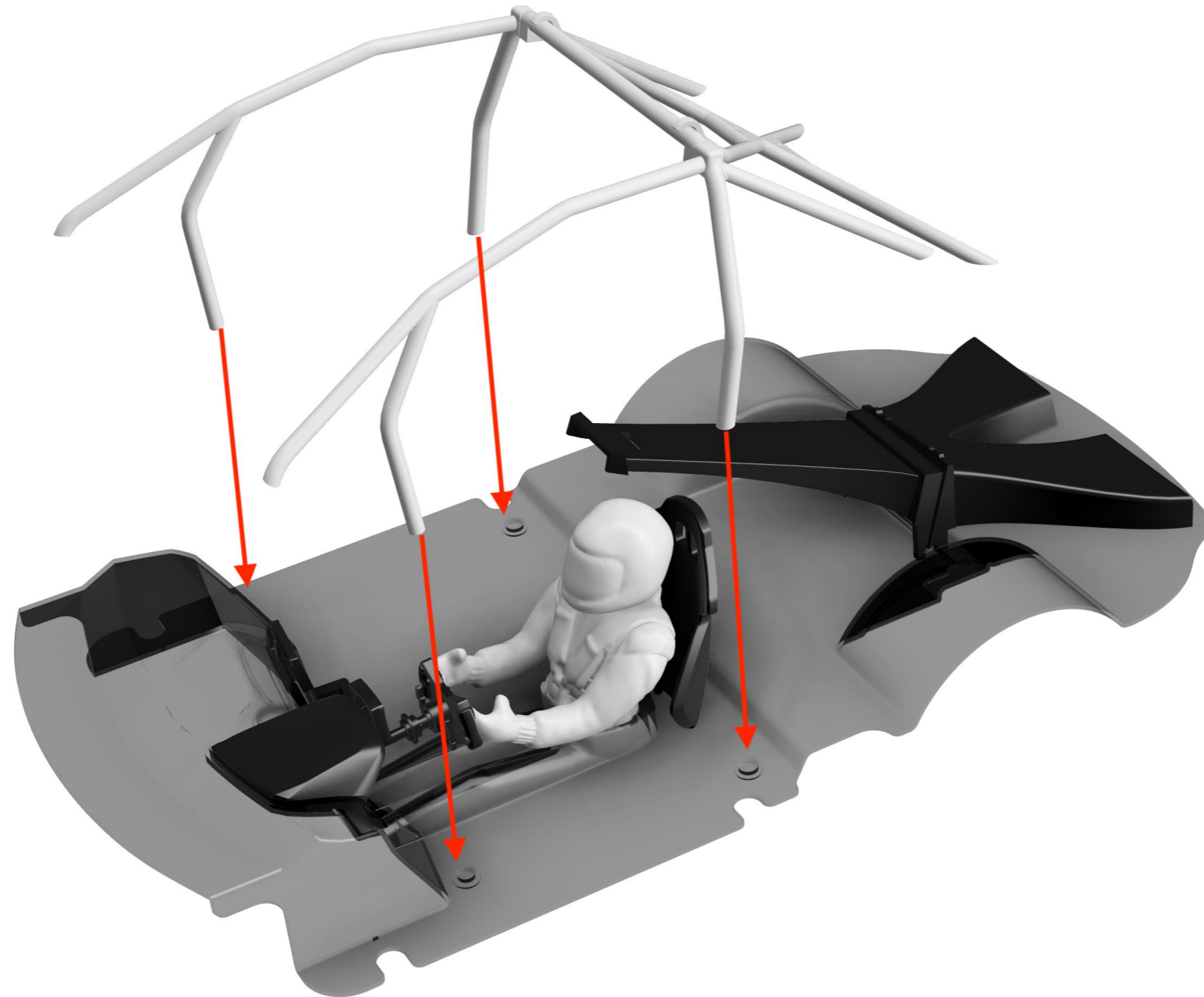



BMW M8 GTE 1/24

COCKPIT ASSEMBLY

FINAL RESULT

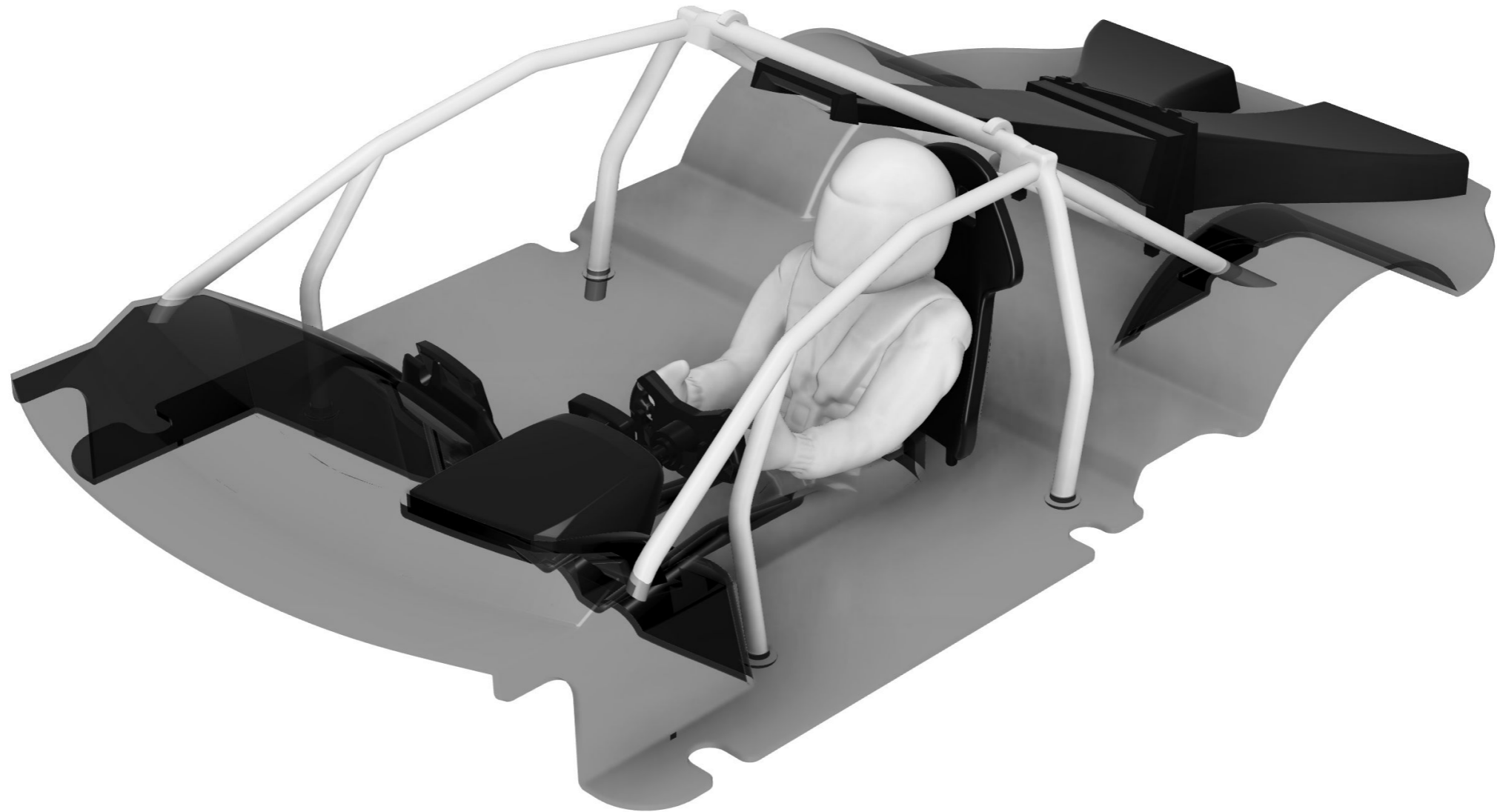



BMW M8 GTE 1/24

BODY ASSEMBLY

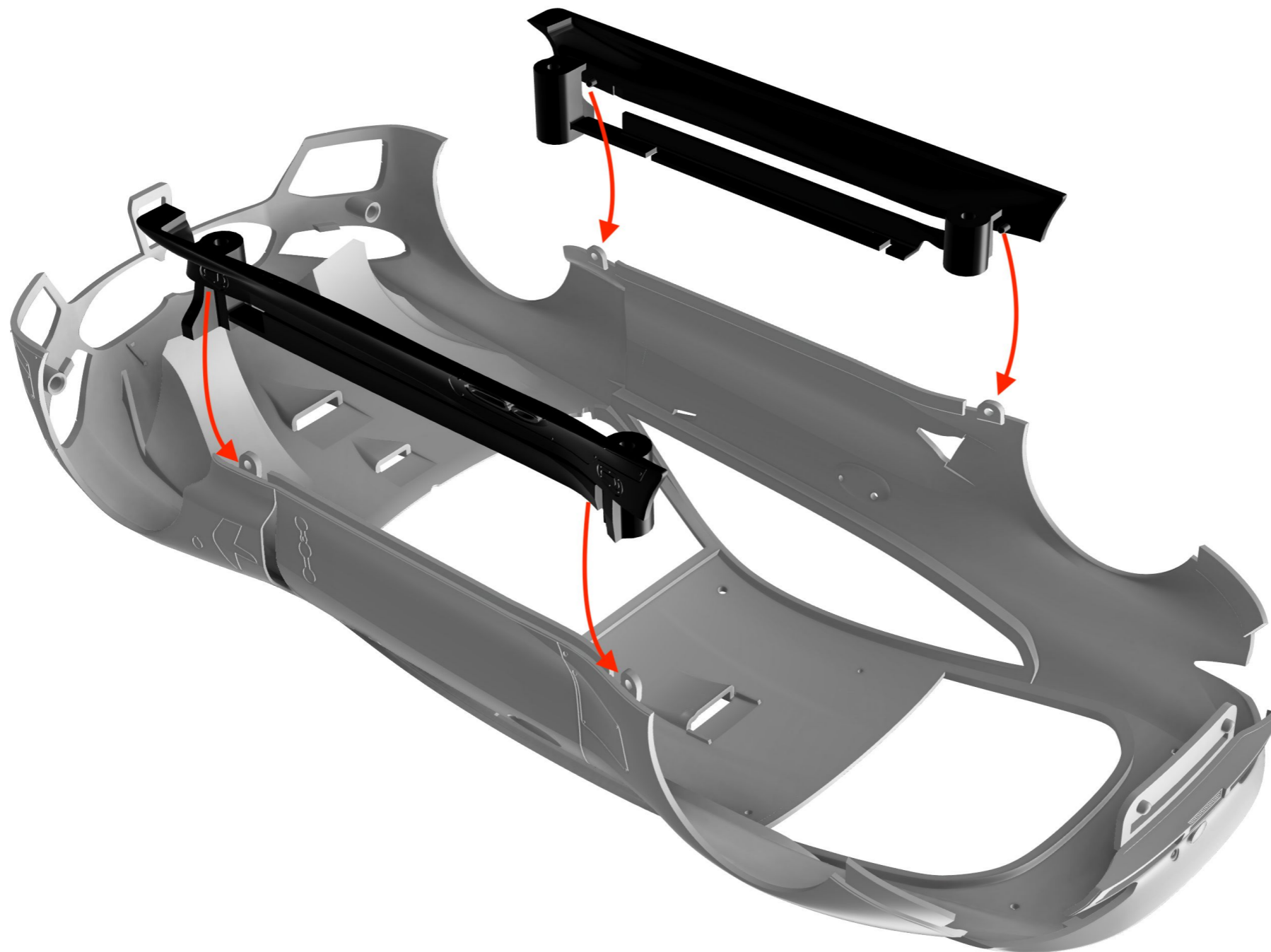



BMW M8 GTE 1/24

BODY ASSEMBLY

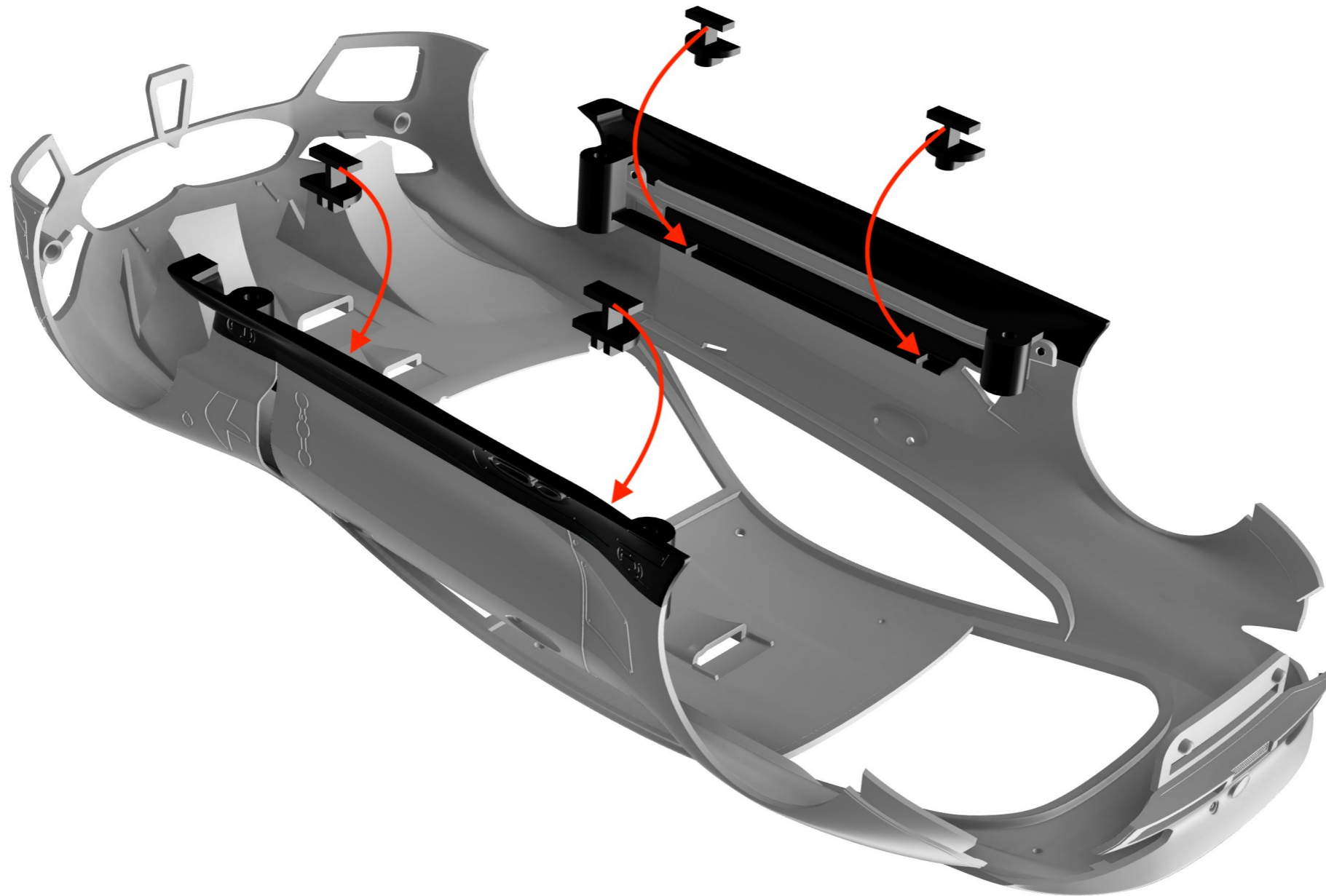



BMW M8 GTE 1/24

BODY ASSEMBLY

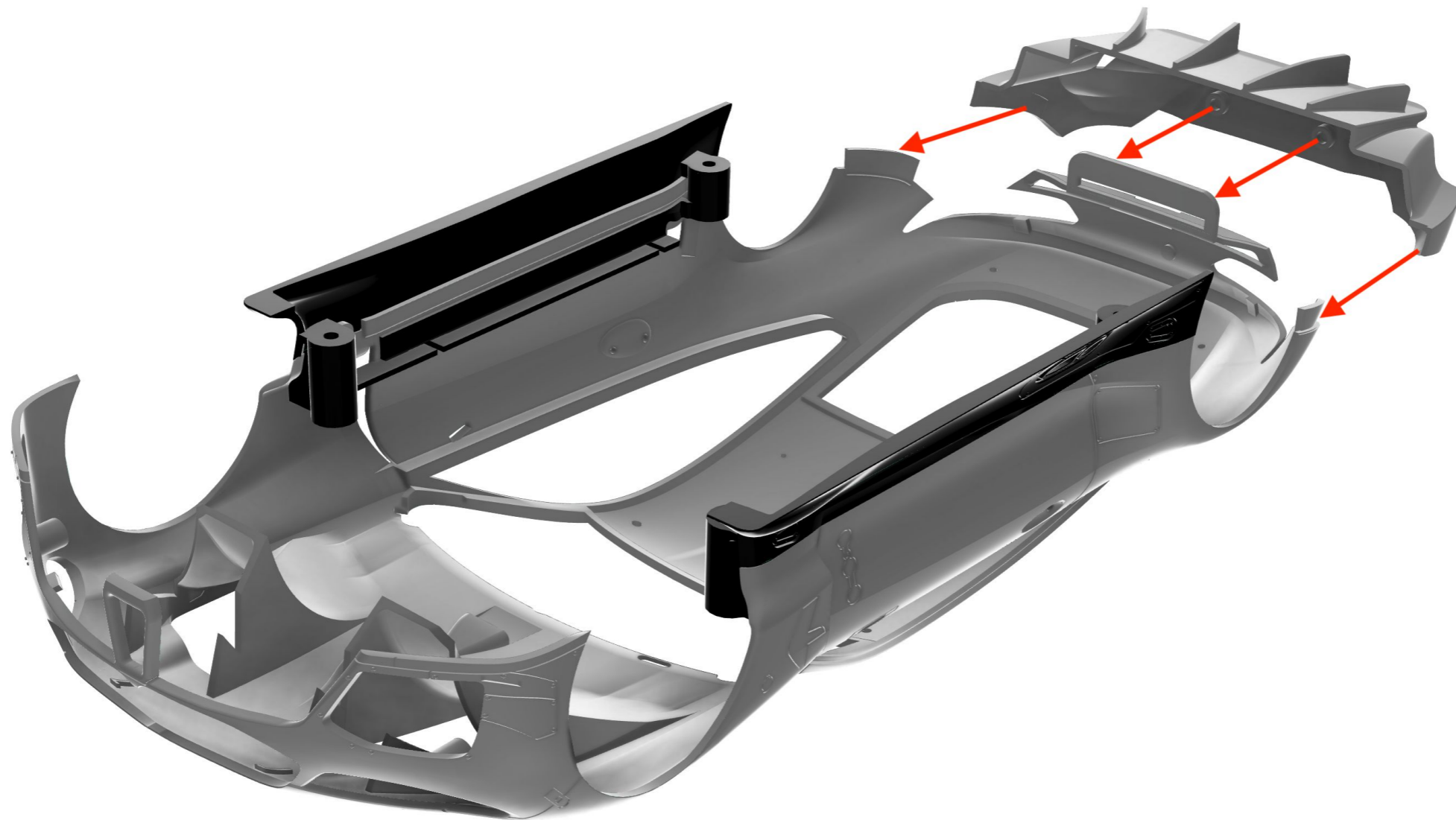



BMW M8 GTE 1/24

BODY ASSEMBLY

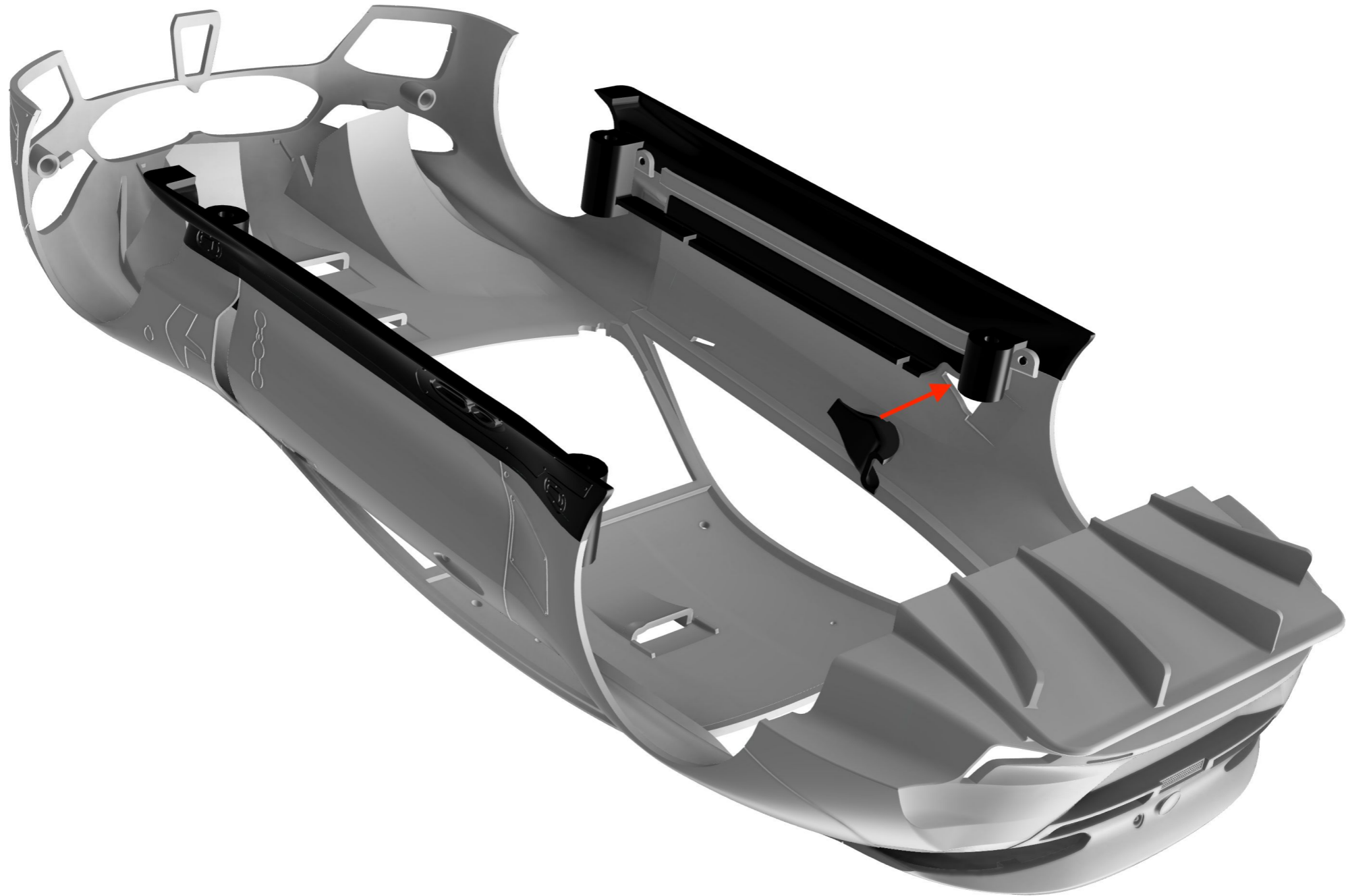



BMW M8 GTE 1/24

BODY ASSEMBLY

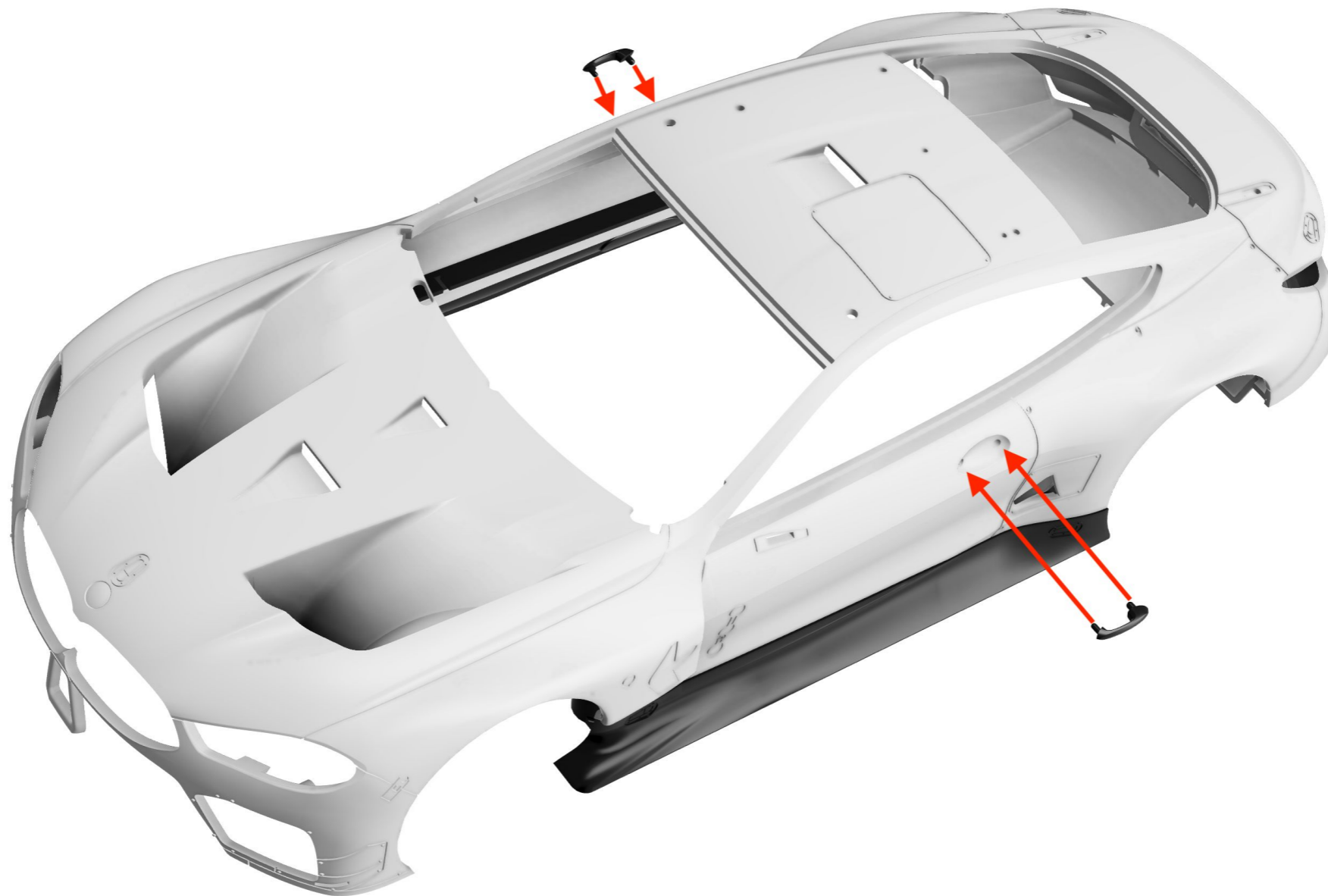



BMW M8 GTE 1/24

BODY ASSEMBLY

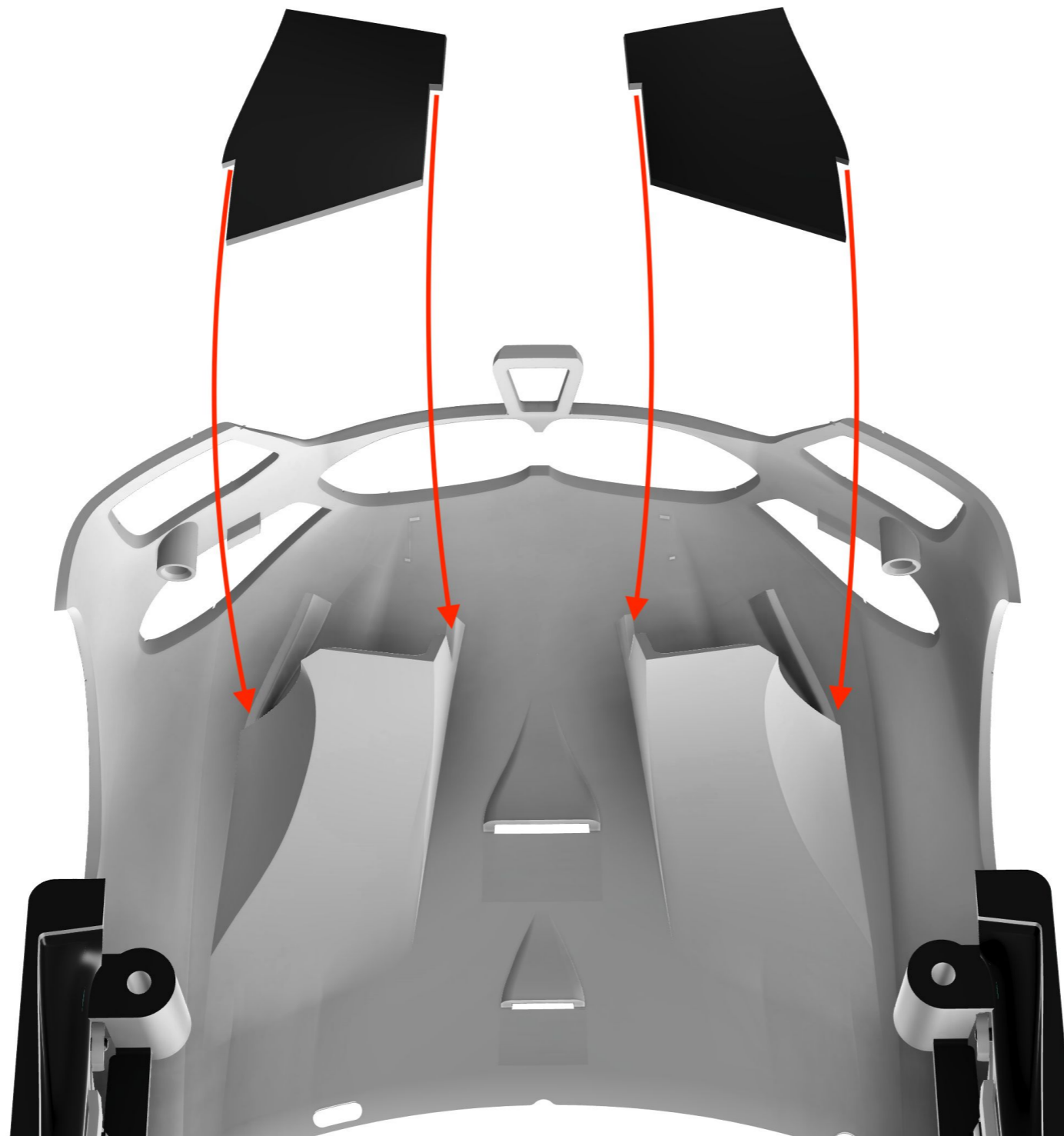



BMW M8 GTE 1/24

BODY ASSEMBLY





BMW M8 GTE 1/24

BODY ASSEMBLY





BMW M8 GTE 1/24

BODY ASSEMBLY

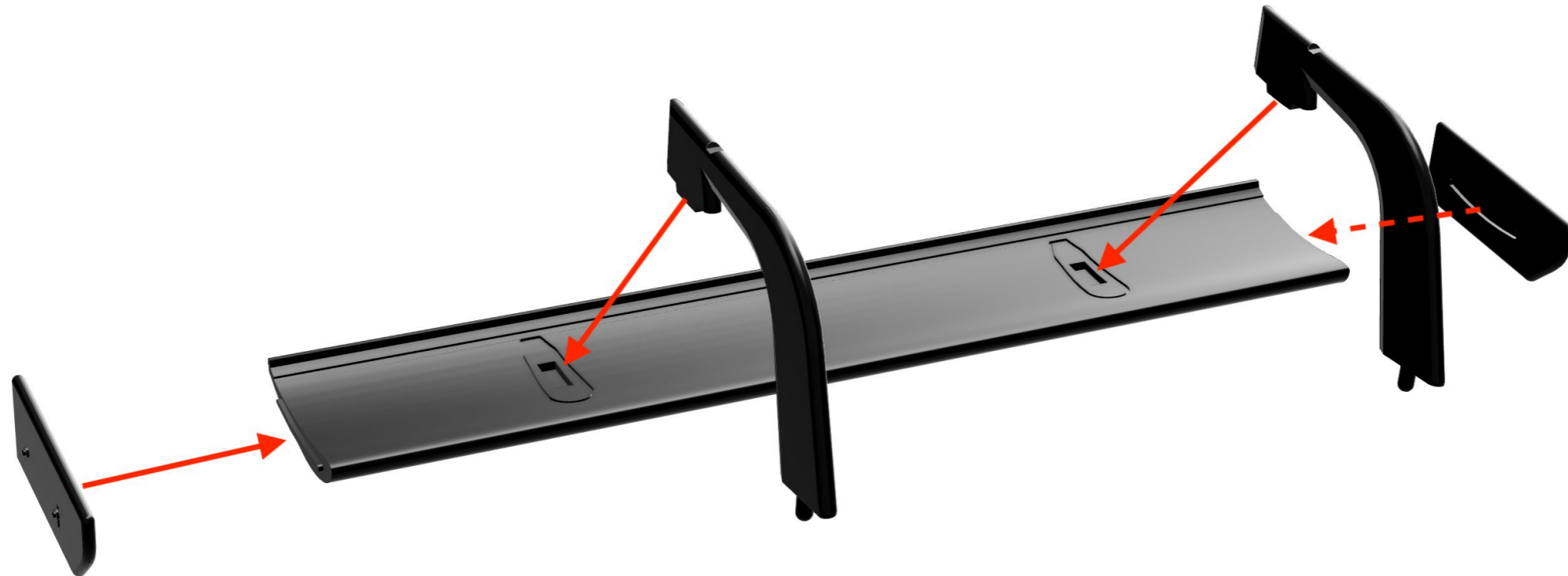



BMW M8 GTE 1/24

BODY ASSEMBLY





BMW M8 GTE 1/24

BODY ASSEMBLY

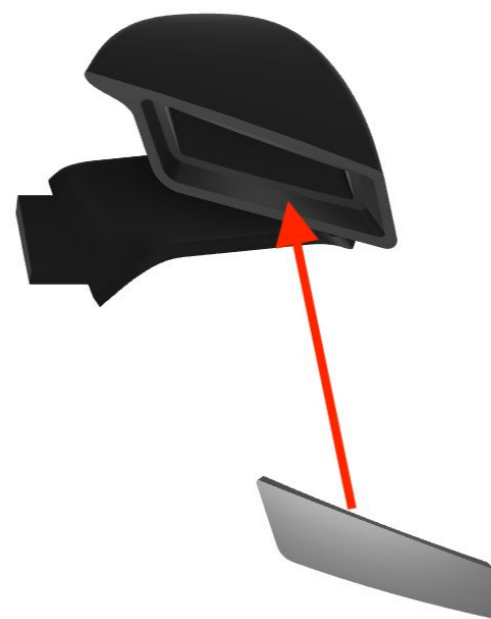
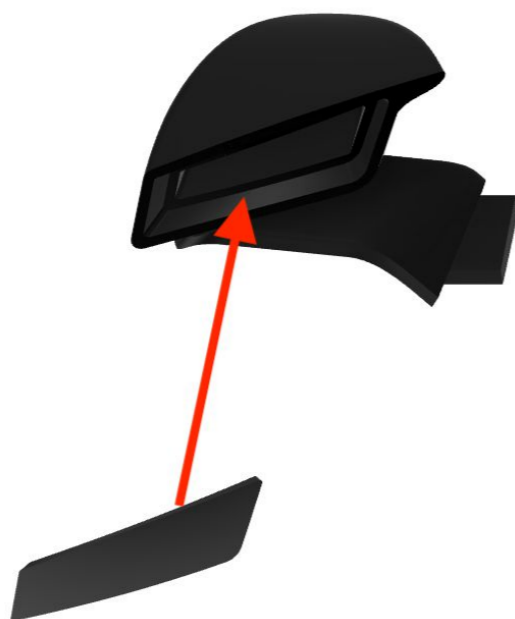

BODY ASSEMBLY

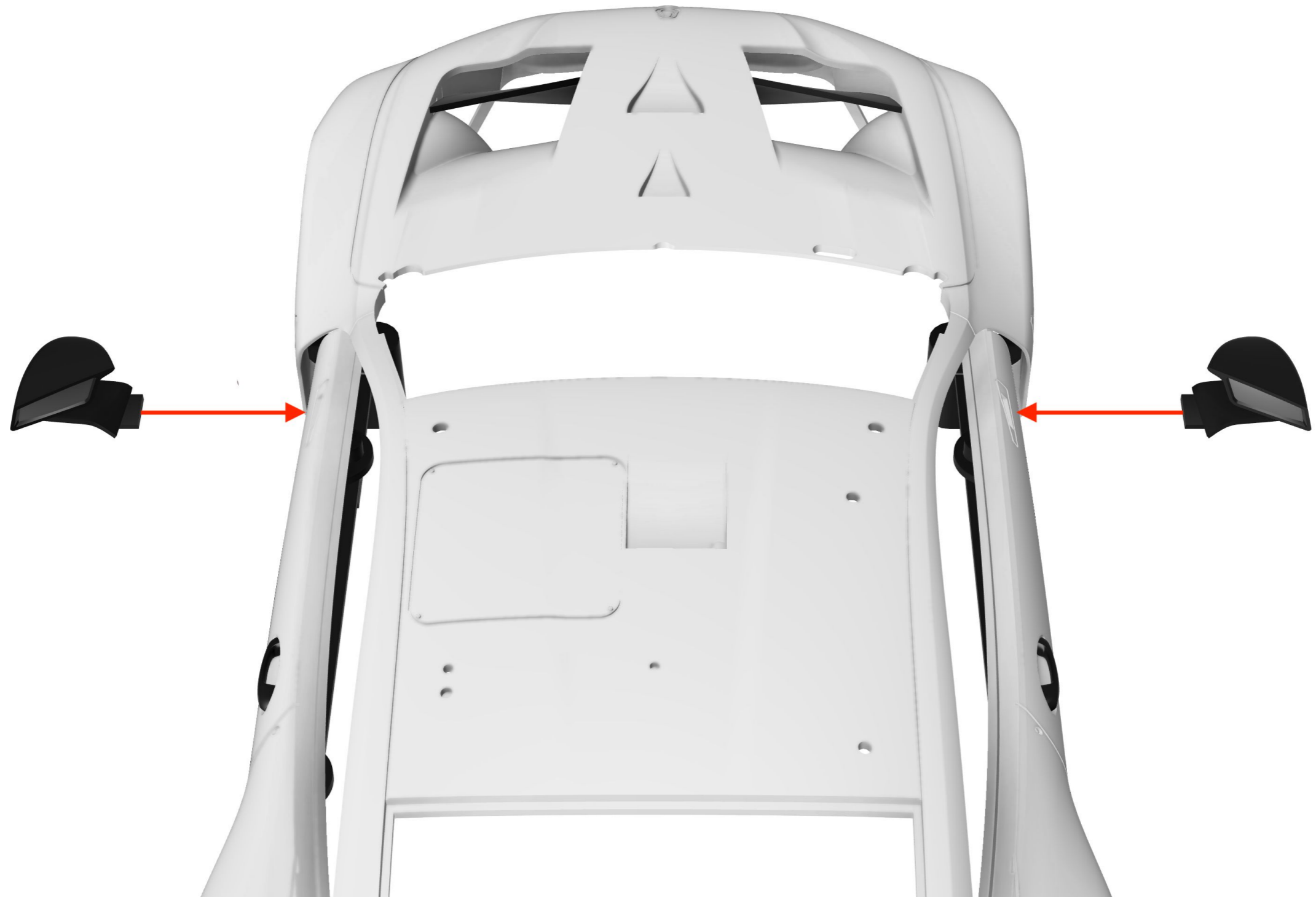



BMW M8 GTE 1/24

BODY ASSEMBLY

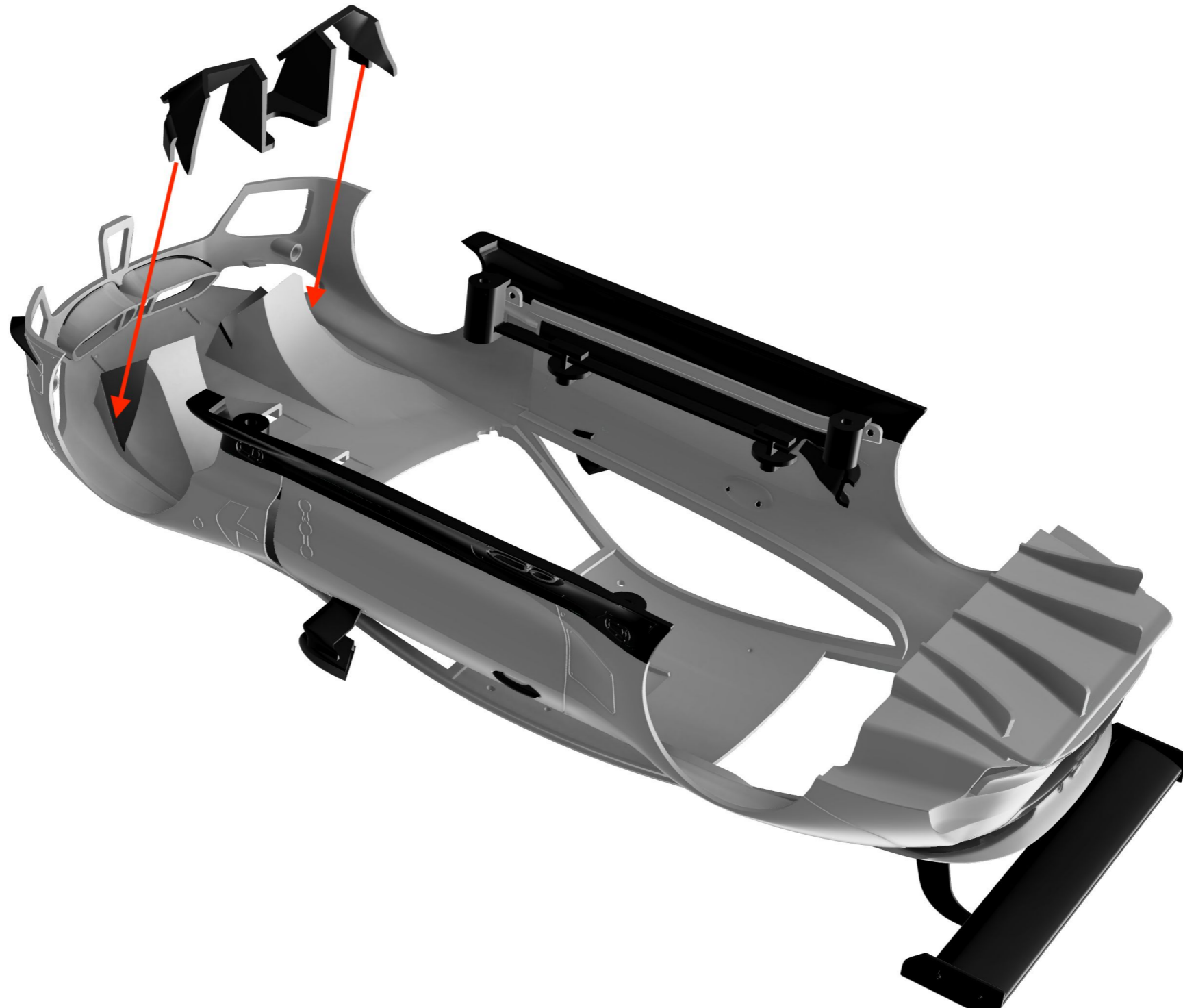



BMW M8 GTE 1/24

BODY ASSEMBLY

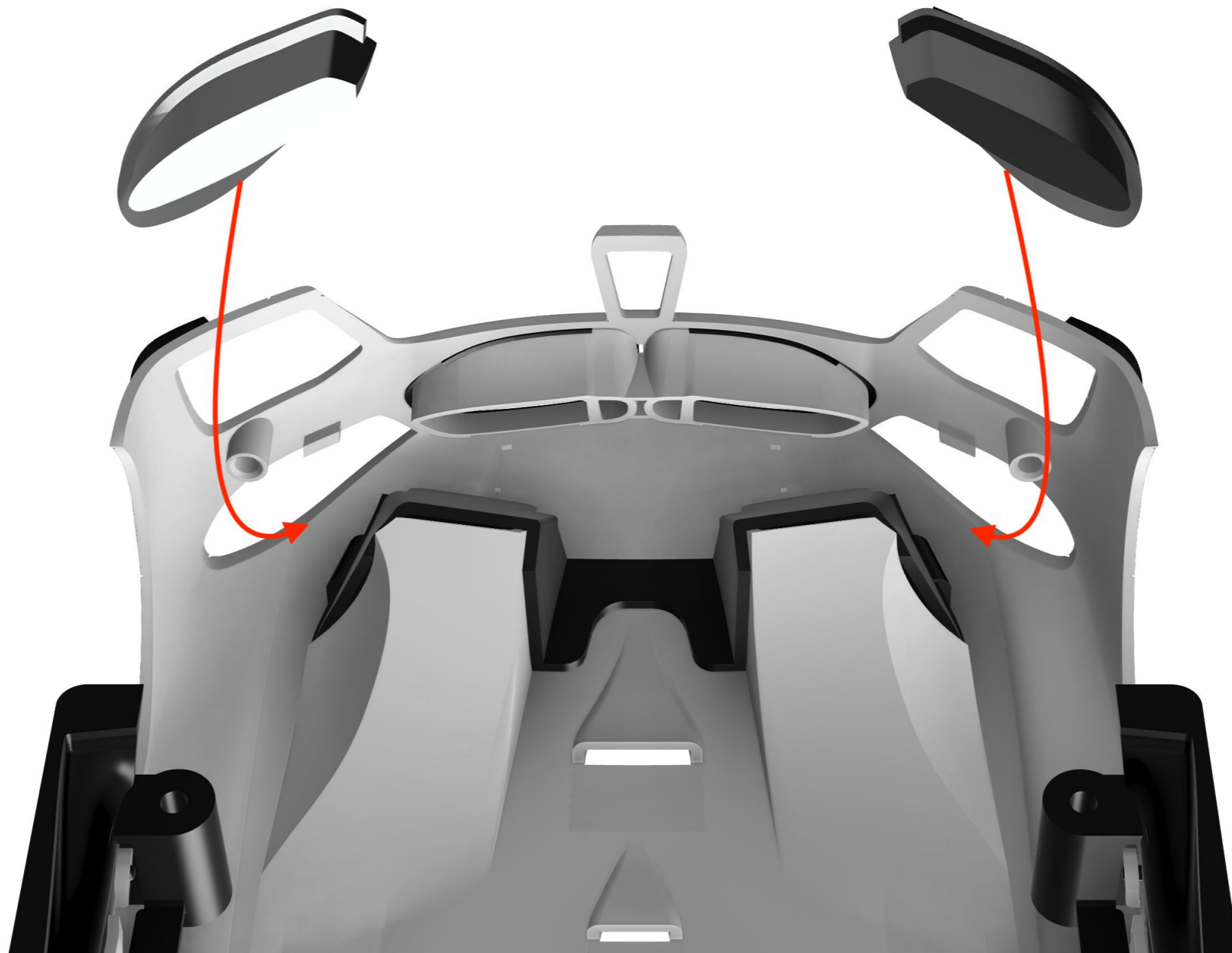



BMW M8 GTE 1/24

BODY ASSEMBLY

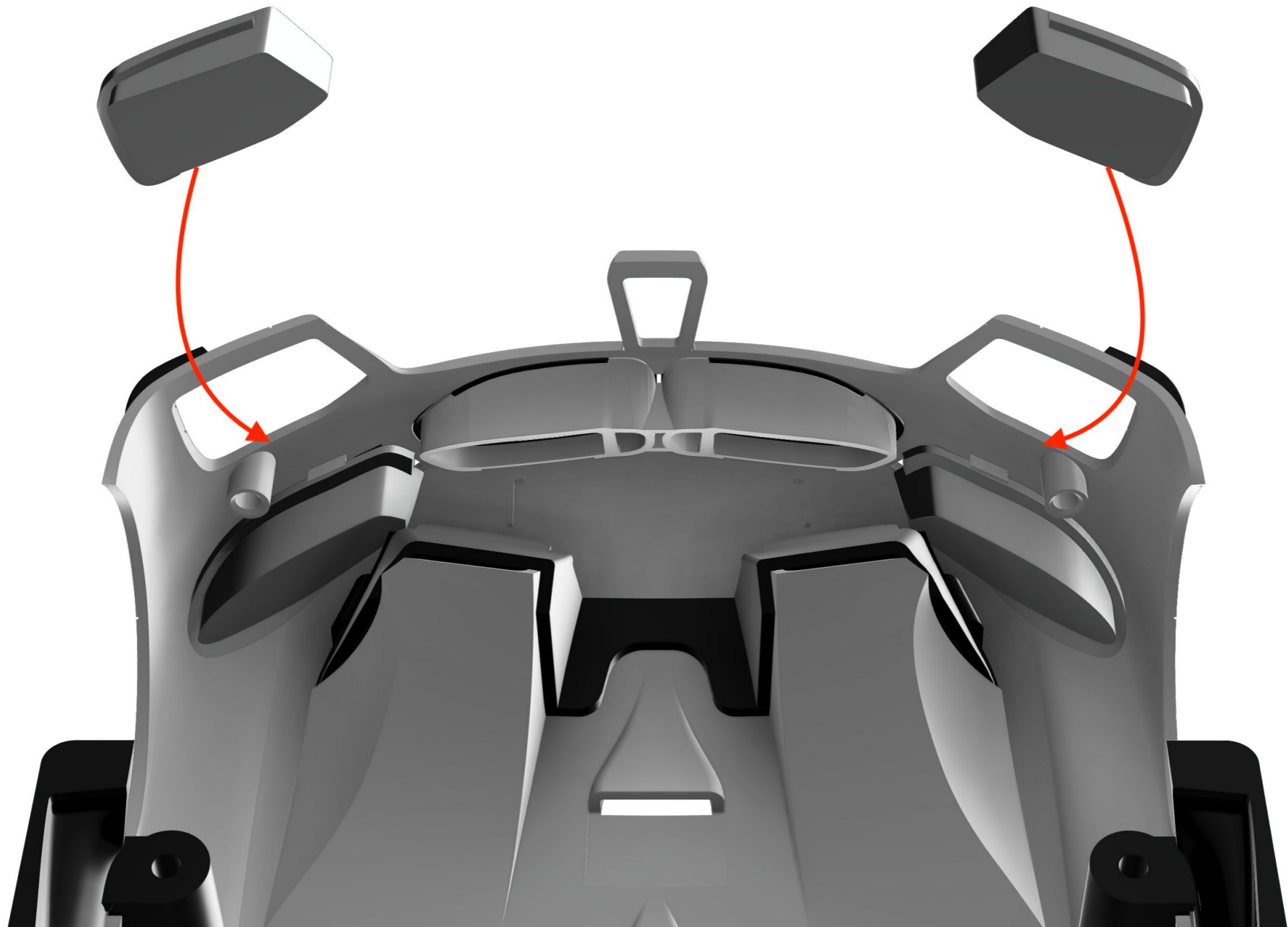



BMW M8 GTE 1/24

BODY ASSEMBLY

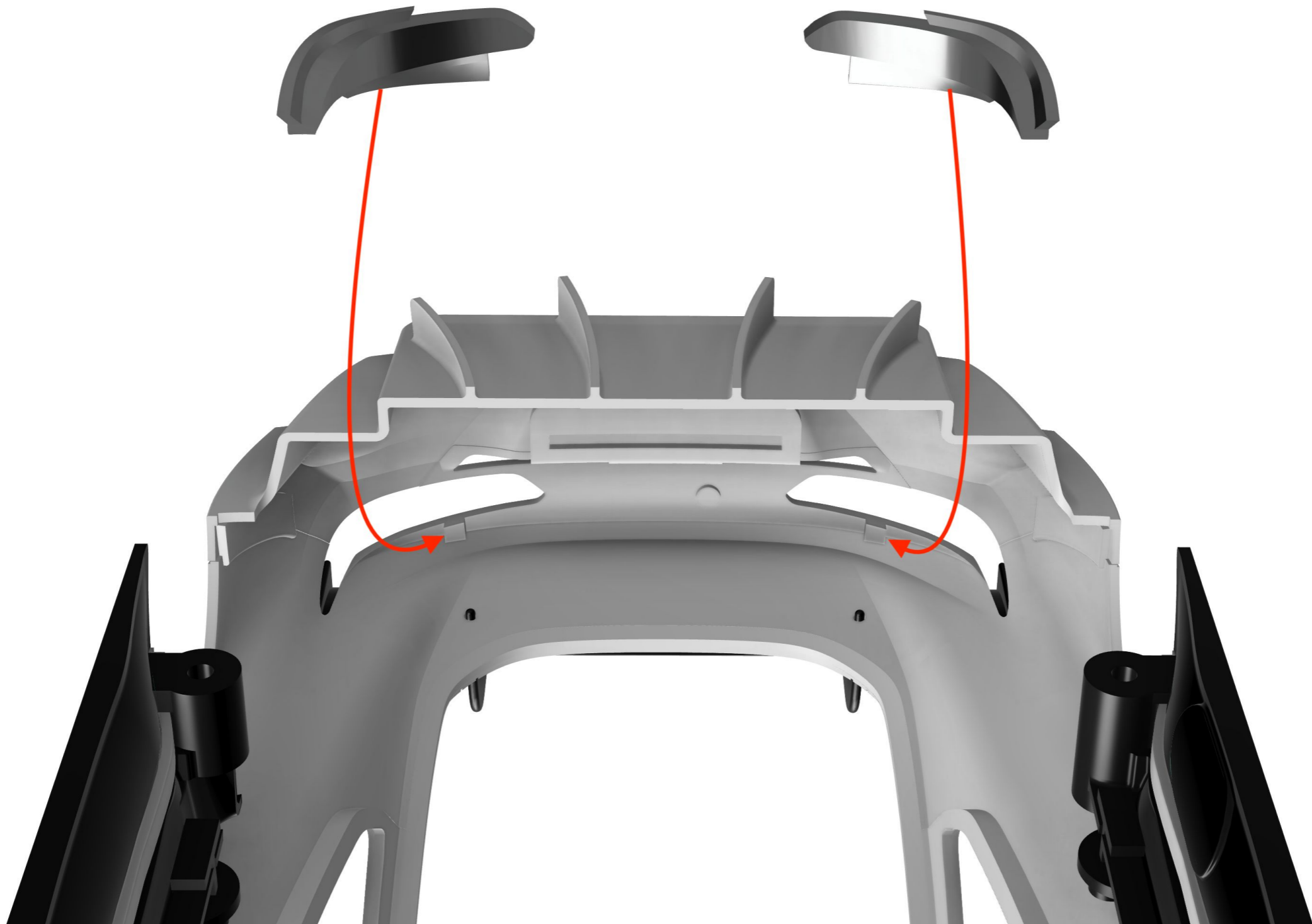



BMW M8 GTE 1/24

BODY ASSEMBLY

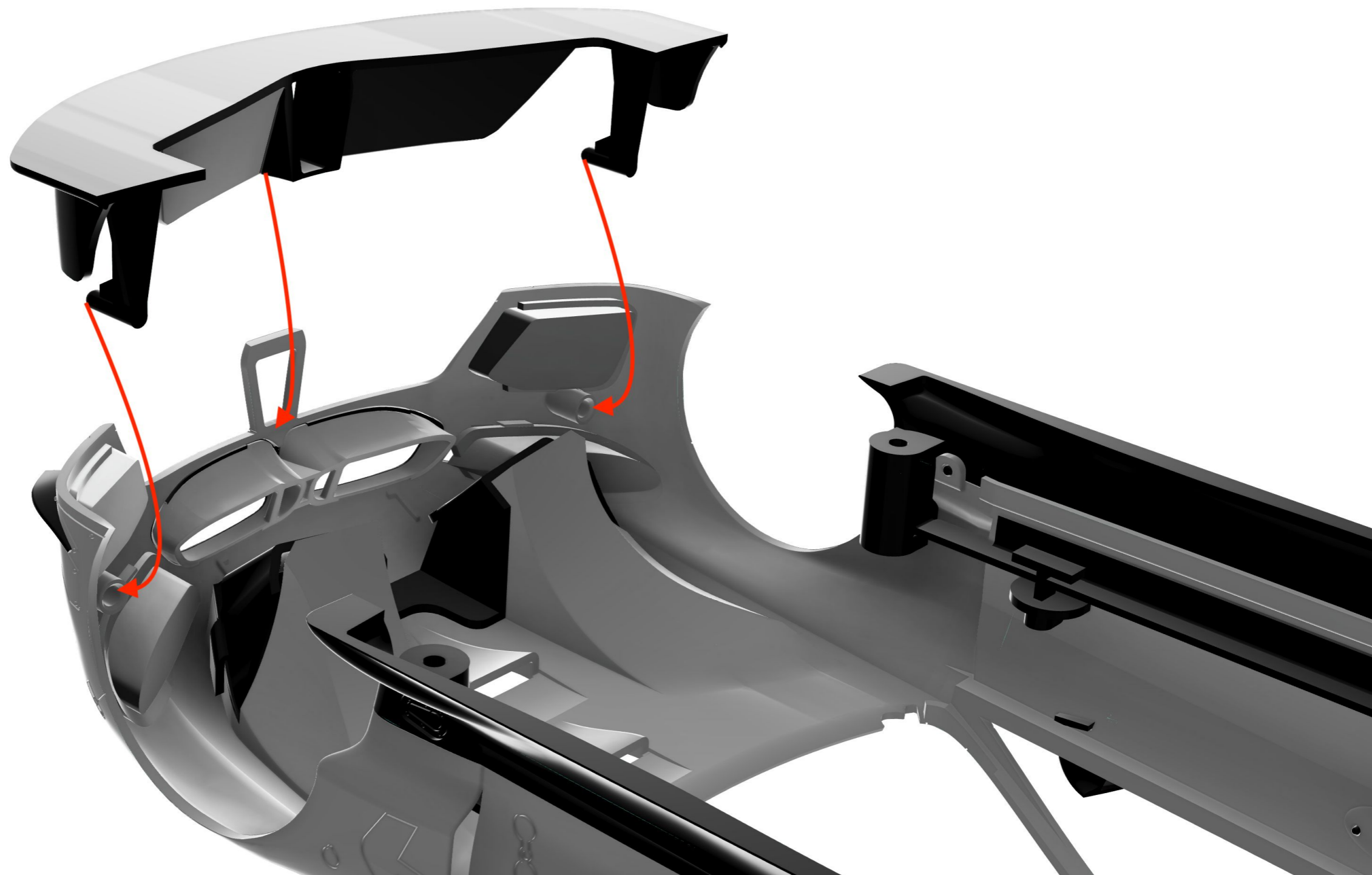



BMW M8 GTE 1/24

BODY ASSEMBLY

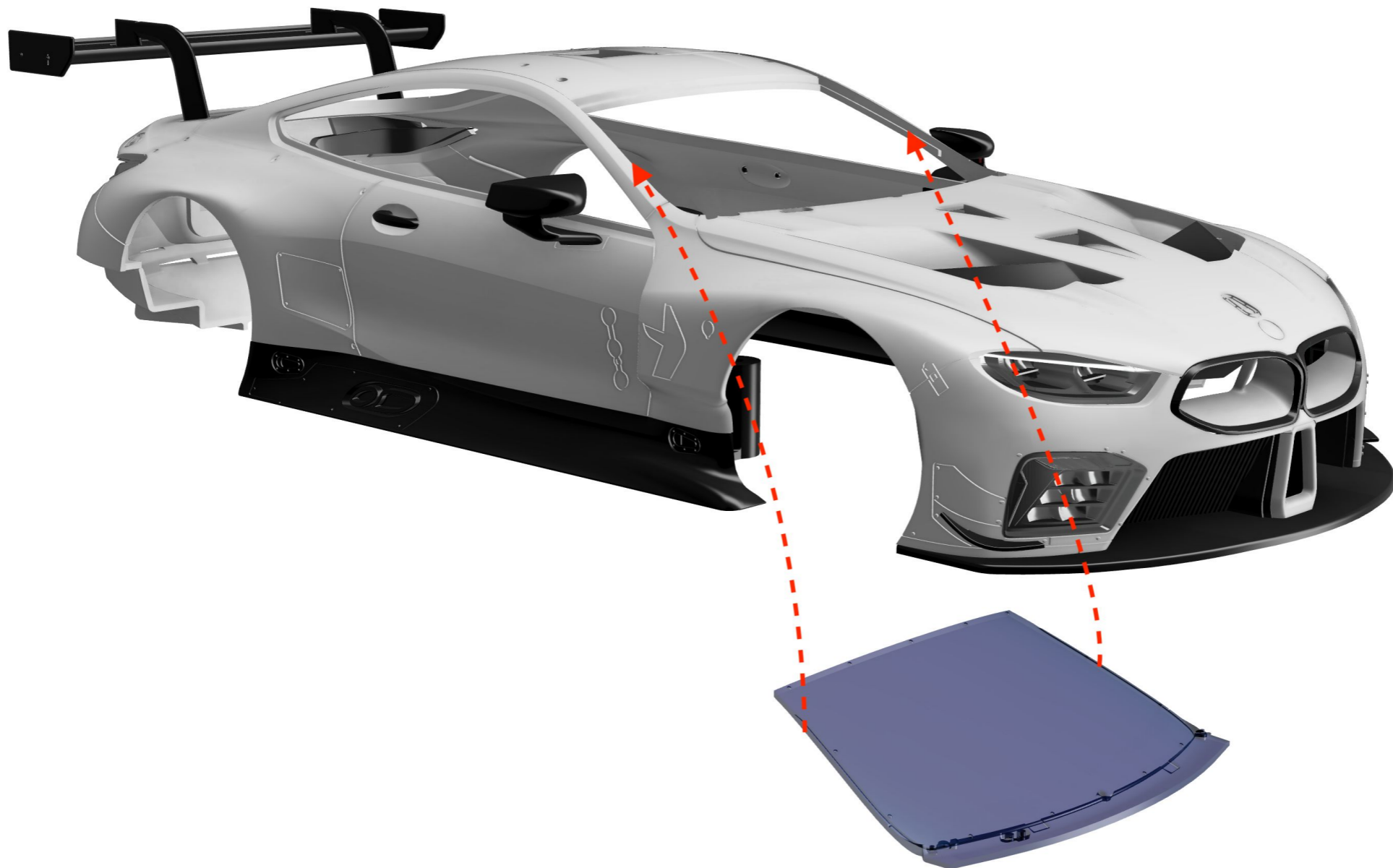



BMW M8 GTE 1/24

BODY ASSEMBLY

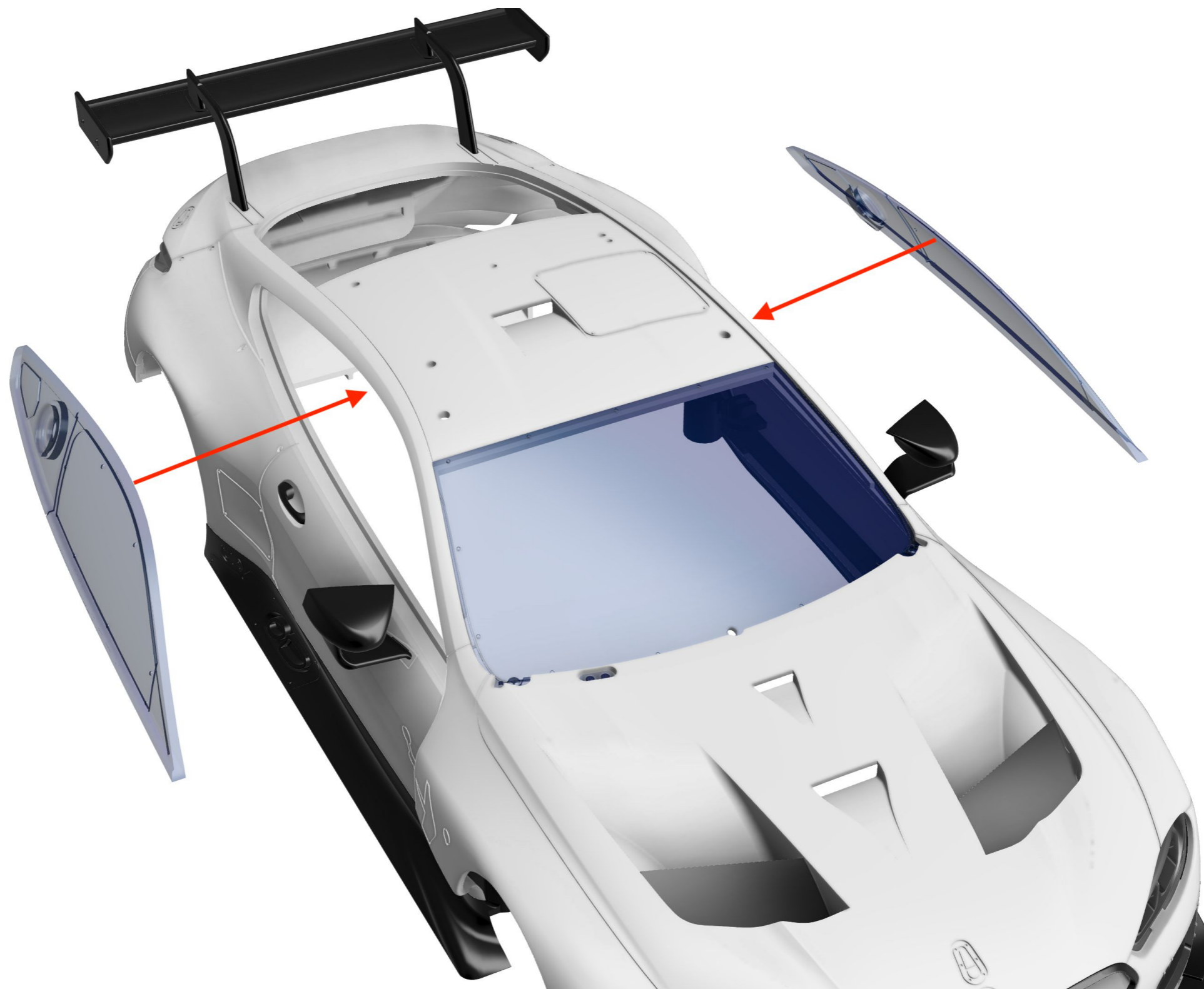



BMW M8 GTE 1/24

BODY ASSEMBLY





BMW M8 GTE 1/24

BODY ASSEMBLY





BMW M8 GTE 1/24

ROD V ASSEMBRIV



BODY ASSEMBLY

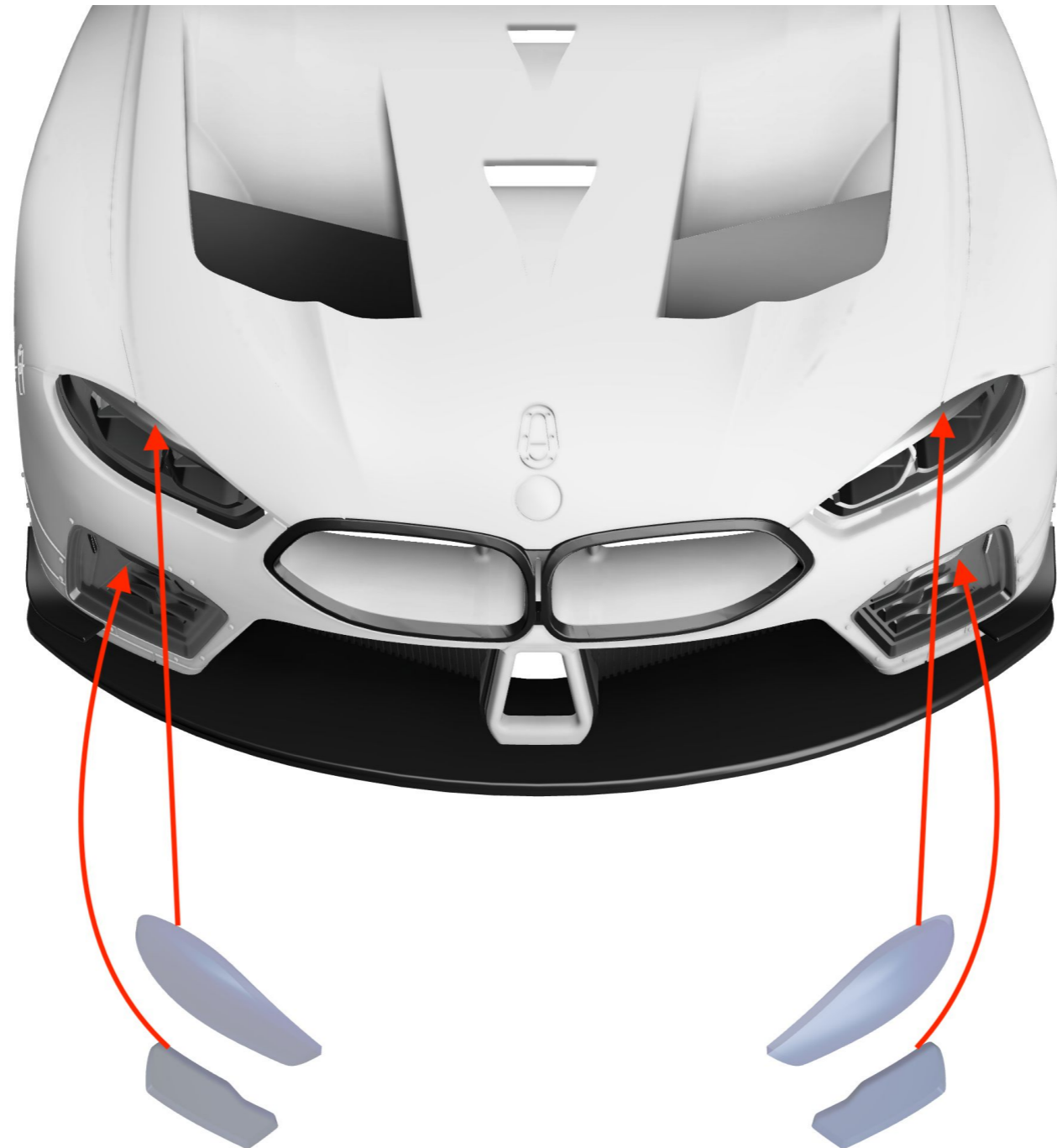

BODY ASSEMBLY





BMW M8 GTE 1/24

BODY ASSEMBLY





BMW M8 GTE 1/24

BODY ASSEMBLY

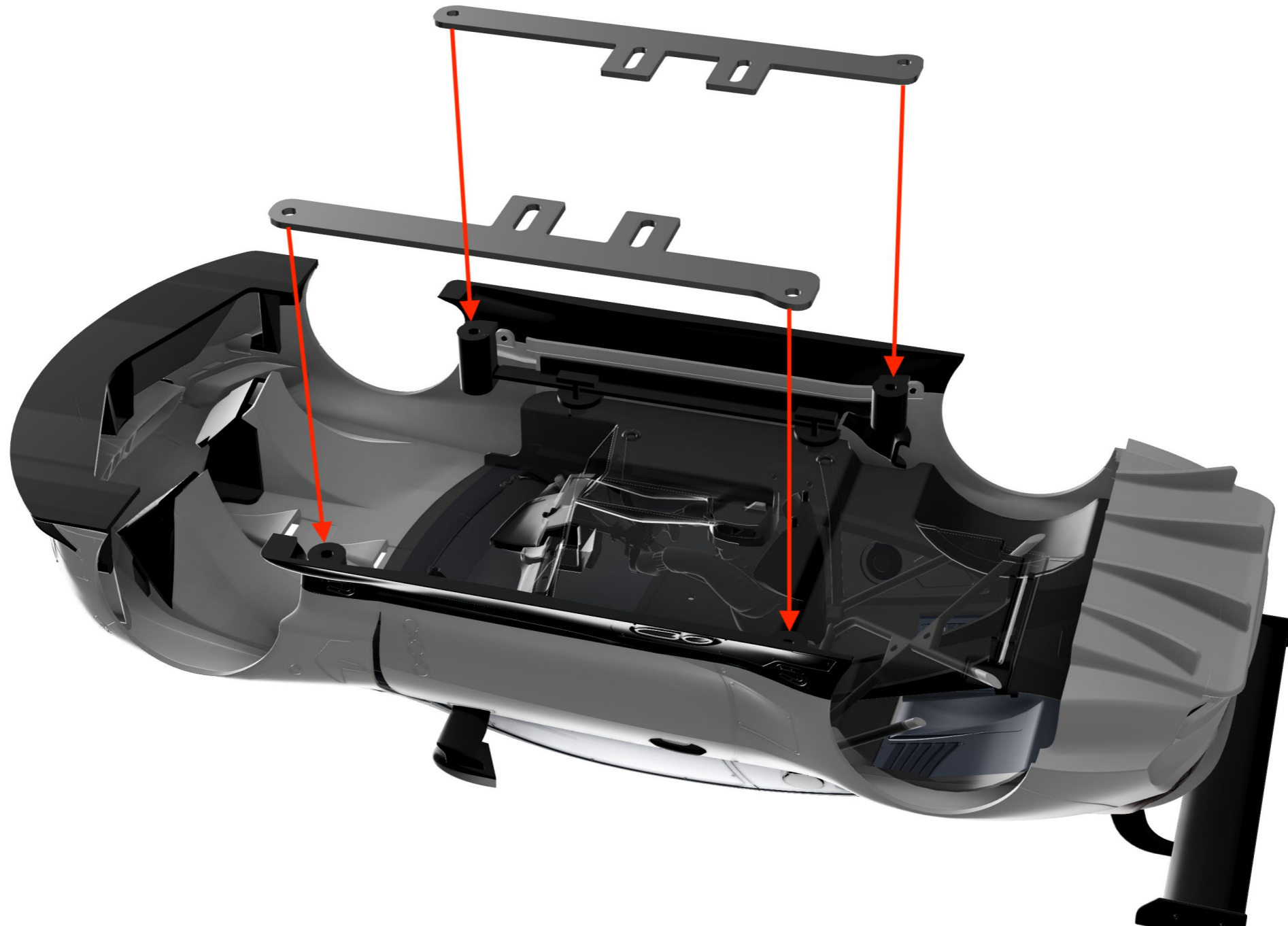



BMW M8 GTE 1/24

FINAL RESULT

